

BOSCARO MANBASKETS

KEY FEATURES

- A** 4 upper & 4 lower rigging points
- B** Removable roof gives you 2 manbaskets in
- C** Fully functional access door
- D** Rollers allows safe transfer up & down side walls
- E** 43.5" high guard railing
- F** Wrap around inner safety railing
- G** Top grade steel construction
- H** 24" lower enclosure minimizes tools from falling
- I** 24" built in tool crib
- J** The EZ™ Test Weight System
- K** Roof has one lanyard connection point
- L** Powder coated finish

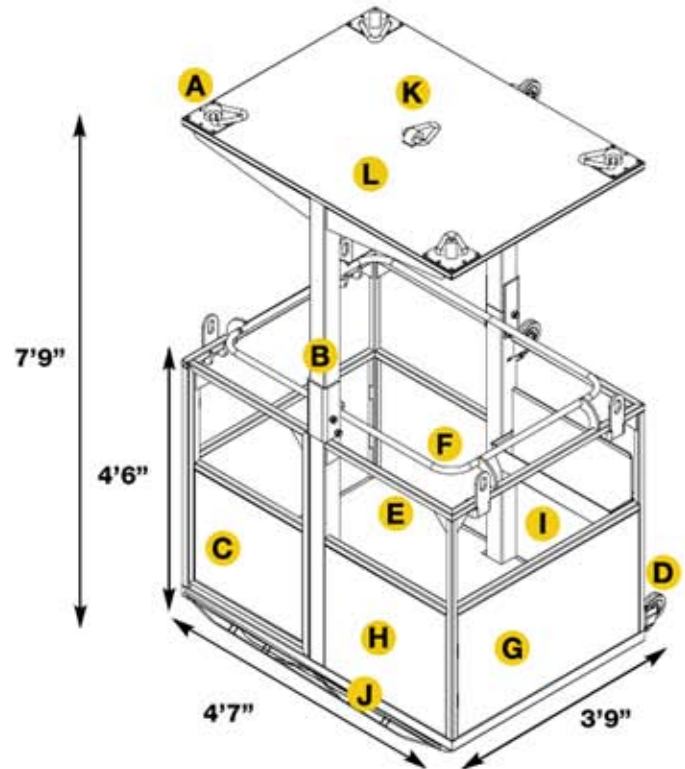

- MEETS AND EXCEEDS ALL OSHA & ASME STANDARDS**
- TESTED TO 9 TIMES THE LEGAL REQUIREMENTS**
- BOTTOM SECTION: 463 LB**
- TOP SECTION: 200 LB**
- TEST WEIGHTS: 815 LB**
- PATENTS PENDING**

FOR INQUIRIES
1-877-852-2192
BOSCAROUSA.COM